

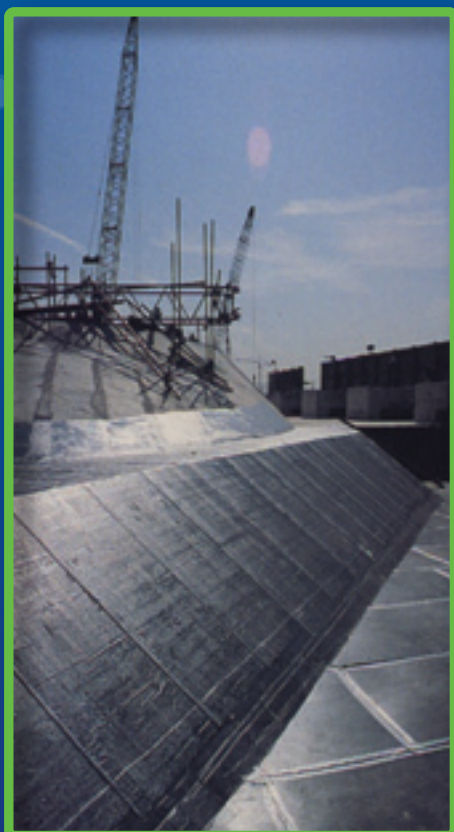

# Sealex

Waterproofing Systems, Sealers & Sealants

## Self-adhesive membrane



### BITUSEAL 1200

#### DESCRIPTION:

Bituseal 1200 is an excellent general purpose self adhesive polyester reinforced, waterproof membrane. It is coated on both sides with a uniquely formulated elastomeric compound.

#### RECOMMENDED USES:

General concrete waterproofing  
Retaining walls  
Foundations  
Bridges  
Tunnels  
Viaducts

#### FEATURES AND BENEFITS:

Self-adhesive, Reinforced, Ease of application

Code:	Description	Pack QTY
BSSA	Bituseal 1200 self adhesive polyester membrane	2mm x 20m x 1m 25/Pallet

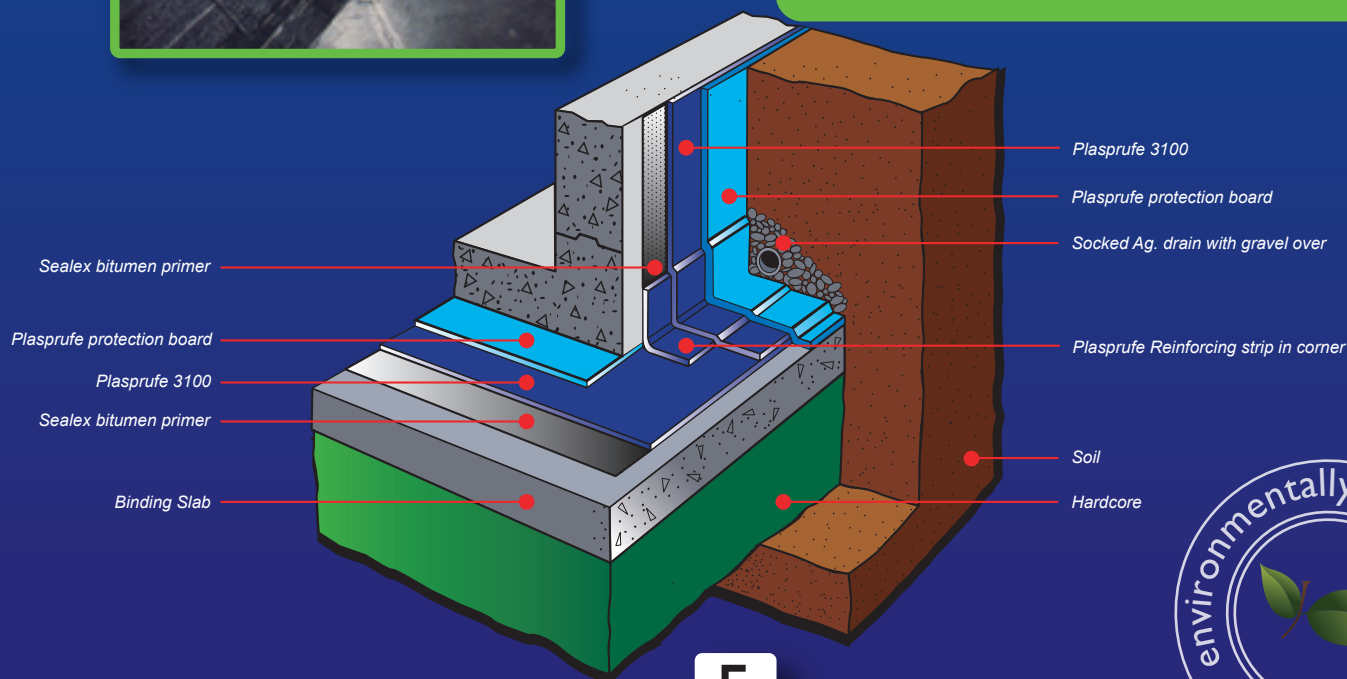

5



5 Balook Drive, Holmwood Business Park,  
Beresfield, NSW 2322  
Fax: 1300 855 598 sales@sealex.com.au

**Phone: 1300 555 955**